



Installation instructions



Benefits of using the system.



Far Infra Red Radiant Heat

Minimal air movement and drafts create real comfort.



Energy efficient

Even, all-around heat uses less energy to provide real warmth.



Fast and responsive

No under heating or over heating.



Simple heating controls

Control the heating using our TherMiser thermostat.



Robust and Reliable

Suitable for high risk & arduous application.



Free up wall space

Create a more spacious and versatile environment.



THE ENERGY SAVING ALTERNATIVE TO
ELECTRIC STORAGE HEATERS & UNDERFLOOR HEATING



WARNING!

Electricity can be dangerous..

you should only attempt installation if you are competent with domestic or industrial wiring. DiscreteHeat recommends that any electrical installation should only be undertaken by a suitably qualified person and in accordance with PART P of the Building Regulations and BS 7671.

Typical ThermaCurve - e parts lists

1. ThermaSkirt TM6 Thermostat (recommended)	4. ThermaCurve radiant heating panels	7. 2 x lengths of cable covers
2. TSE 101 Connection PCB & Case	5. 2 x lengths of TSE 075 heating cable	
3. Connection & termination covers	6. Corner Connections (internal, external or odd-angle)	

Tools required:

1. A suitable metal cutting saw, preferably a chop saw.	8. Heat gun.
2. DiscreteHeat rotary de-burring tool (incl. in spares kit).	9. Plastic or timber faced mallet.
3. An accurate, quality tape measure (Grade 2 or better).	10. Rawplugs and/or plasterboard fixings with screws.
4. A pair of long nose pliers or similar.	11. 22mm plastic pipe cutter.
5. A Stanley knife/box cutter and/or plasterboard saw.	12. 7mm drill bits.
6. Power drill with hammer action.	13. Pick Tool.
7. Power screw driver/impact driver.	14. Pry bar.

Do's and don'ts

DO Carefully check you have all the parts required by your design systems before you start cutting.

DO Check all profile measurements twice before cutting: see diagram on page 5 (unless provided pre-cut).

DO Ensure the power supply to the switched fused spur for the controls is installed by a qualified electrician.

DO Prepare the cable ends before inserting into the profile panel. The cable is difficult to strip and mistakes are hard to correct once the cable is fixed into the cable channels.

DO Make sure the power is OFF before connecting the termination PCB

DON'T forget to chamfer the edge of the cut ends of the cable channels using the de-burring tool (provided in the spares kit).

DON'T forget that aluminium expands (by about 1mm per meter), so make sure the ends of the profile are not hard up against any fixed features.

DON'T put the metal covers on or power up the unit/cables until the end of the installation!

Providing a safe electrical supply

A typical domestic wiring example

Wiring to a suitable thermostat unit should be by a suitably certified or electrically competent person. Once isolated from the mains at the switch fused spur, installation of the ThermaCurve - e components can commence.

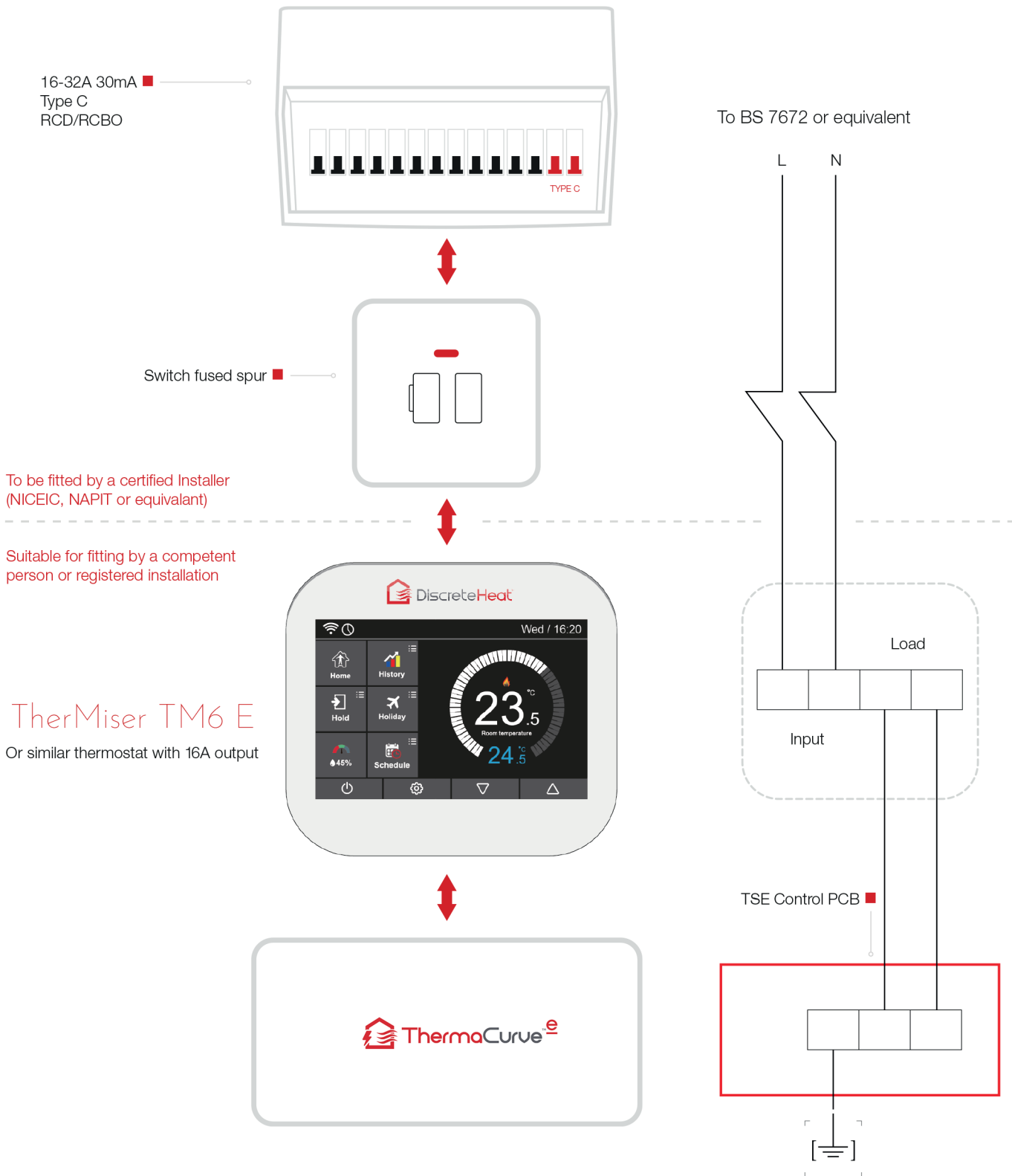

Schematic for illustration only. Check Thermostat instructions for actual wiring details

Installing the Power Connection PCB Bracket

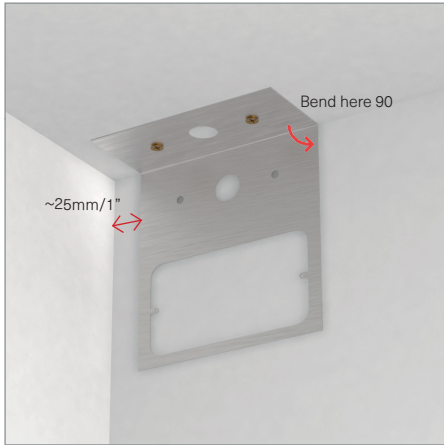

1. Mount the 'Easy Bend' PCB bracket approx. 25mm (1") from the corner of the wall/start of run, and up to the ceiling. Do not over-tighten the 2 mounting screws so the bracket can still slide on the slots. For mid-wall installation, see separate instructions provided.



2. When secure. Bend the bottom edge up at 45° to form the angled bracket.

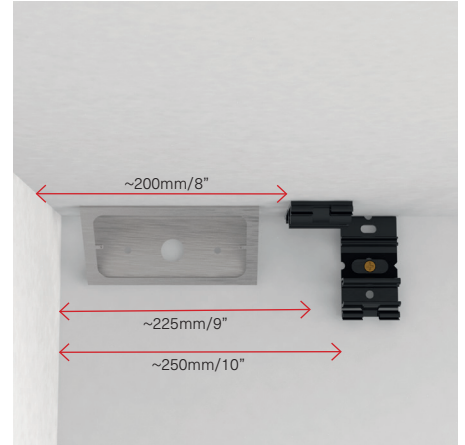

3. Installing the 1st Wall & Ceiling Brackets.

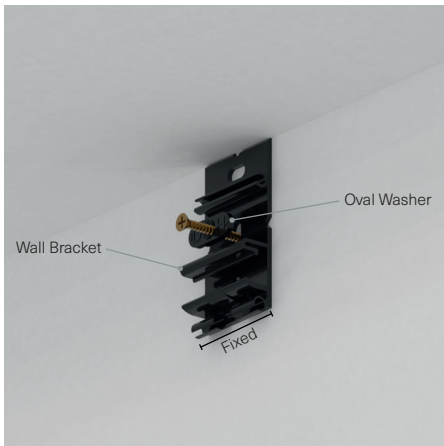

4. The Wall bracket is fixed using the centre slot (with teeth) and the oval washer. Check its secured.



5. The ceiling bracket is secured (but slides) using the lower slot (no teeth) and the round washer. Check bracket still slides.

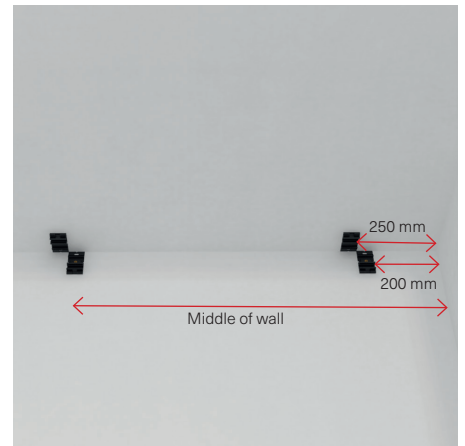

6. 2nd & 3rd Brackets.
The 2nd set of brackets is fitted in the middle wall length. The 3rd set is fitted ~200mm from the end/ corner of the wall.

Preparing the ThermaCurve Profile

When cutting the ThermaCurve profile, the following allowances should be made:

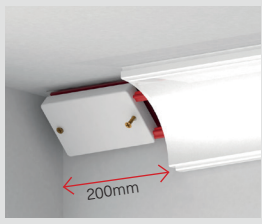
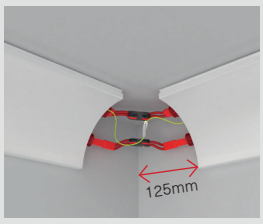
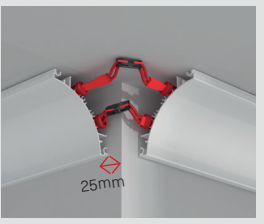
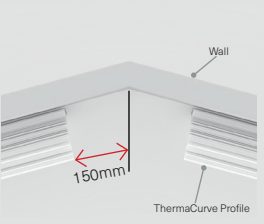
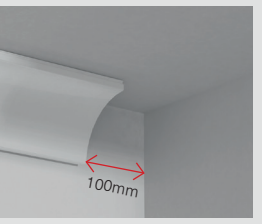
Power Connection / PCB	Internal Corner	External corner	Special Angle	End Termination
Wall length MINUS 200mm/8"	Wall length MINUS 125mm/5"	Wall length MINUS 25mm/1"	Wall length MINUS 150mm/6"	Wall length MINUS 100mm/4"
				

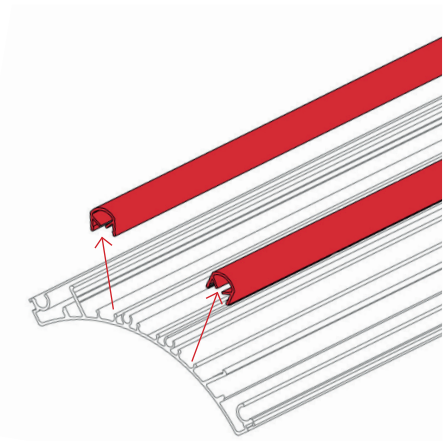

1. When cutting the ThermaCurve profile, remove any back capping to prevent swarf or chips becoming trapped, which could damage the heating cable when inserted.

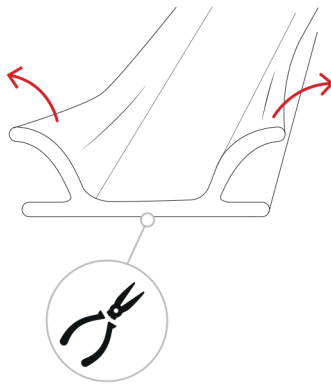

2. Using a pair of long nose pliers or similar, 'splay out' the cable channel at the ends to create a wider, 'bell mouth' opening. This prevents the heating cable from snagging.

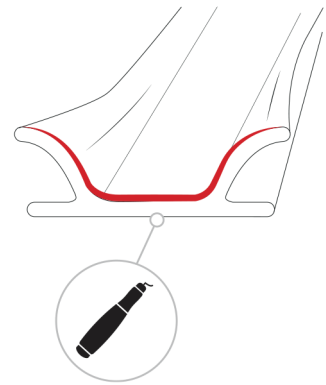

3. De burr! Using the rotary de burring tool (from the spares kit) chamfer the cut ends. Note; failure to follow 8.2 & 8.3 may invalidate your warranty.

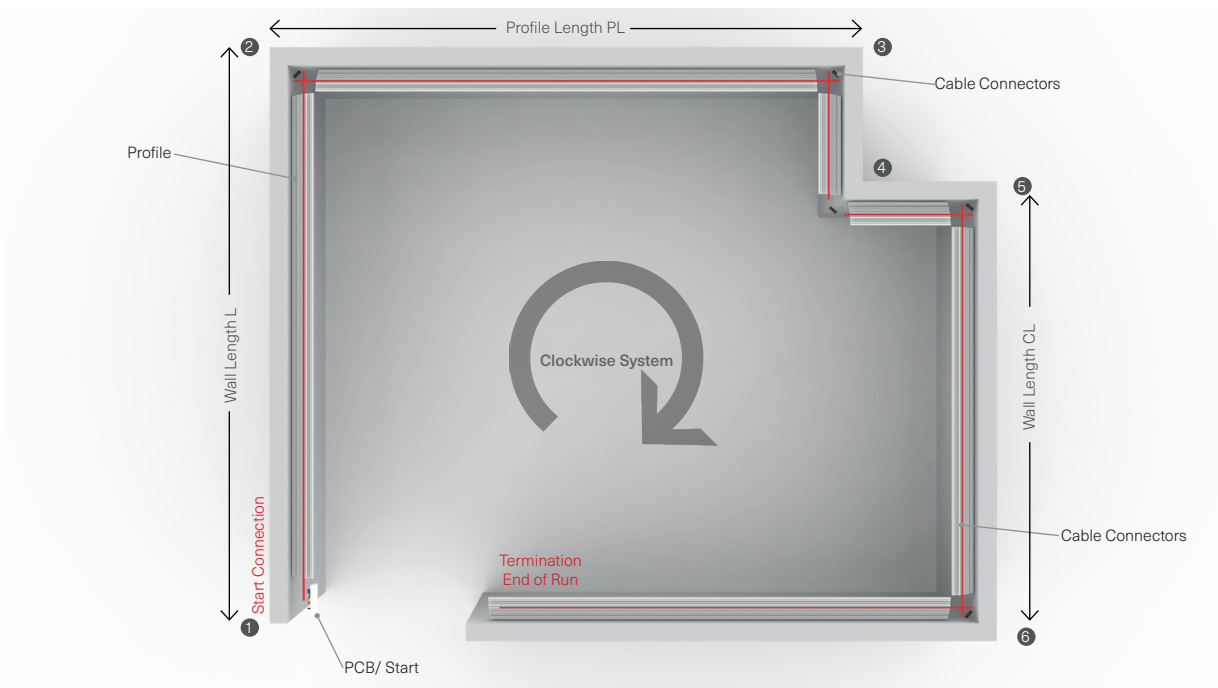

Preparing the cable lengths (if not supplied factory cut)

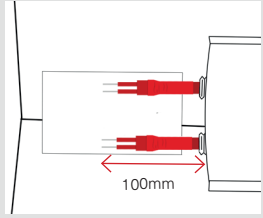
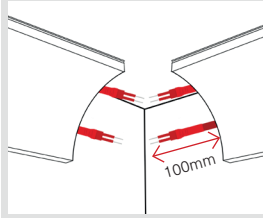
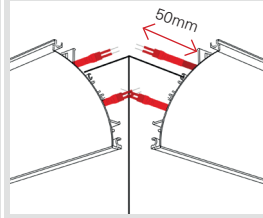
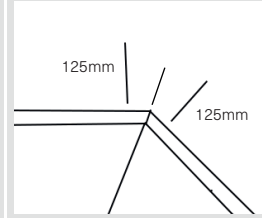
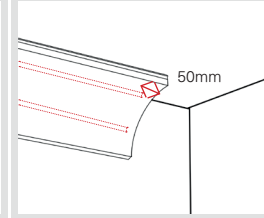
Power Connection / PCB	Internal Corner	External corner	Special Angle	End Termination
Wall length MINUS -100mm/4"	Wall length MINUS -25mm/1"	Wall length PLUS +25mm/1"	Wall length MINUS -25mm/1"	Wall length MINUS -50mm/2"
				
Or: Profile Length PLUS +100mm/4"	Or: Profile Length PLUS +100mm/4"	Or: Profile Length PLUS +50mm/2"	Or: Profile Length PLUS +125mm/5"	Or: Profile Length PLUS +50mm/2"

Preparing the Power Connection Cable end

Note: Heating cables are usually supplied pre-prepared. If not, prepare the cable ends before inserting into the ThermoCurve profile; the cable is difficult to strip and mistakes are hard to correct once the cable is in the cable channels.



1. Remove the outer red silicone jacket to reveal approximately 80mm (3 1/4") of black inner core.

2. Split the black inner core down the middle and separate.

3. Using a Stanley knife (box cutter) or similar at a shallow angle, slice away the black core to reveal the inner conductors; NOTE; safety gloves and eye shields should be worn and always cut away from yourself.

Preparing the Power Connection Cable end

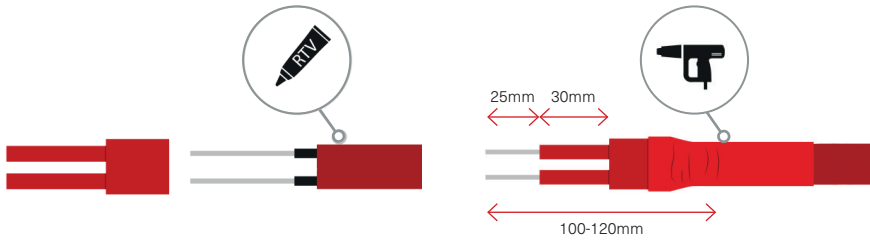

3. Apply some RTV silicone glue/sealant and slide the silicone 'trousers' over the conducting cores. Secure the trousers to the outer silicone jacket.

4. Using an air heat gun, heat shrink the trousers to the cable to create a permanent joint.

Install the heating cables – First section



1. Lay the 1st ThermaCurve profile face down (on a soft, clean surface to prevent paint damage).

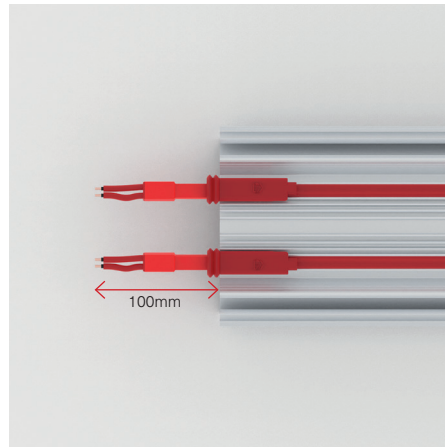

2. Insert the heating cables such that the trouser PCB connection end is protruding 100mm from the end. Secure the cables into the cable channel using the clear polycarbonate back capping.

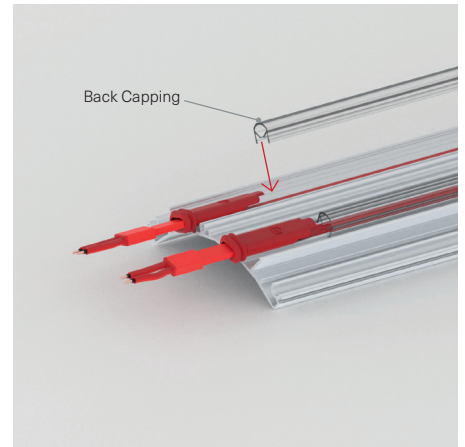

3. Insert the heating cable into the channel, and secure in place using the clear back capping. The last section of back capping can be cut to length.

Preparing the cable ends – Terminating a single straight length (For onward section see 12)

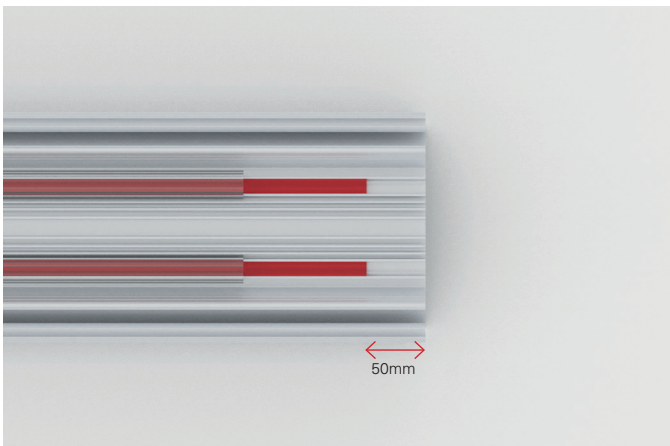

4. If the ThermaCurve is heating a single straight wall (no corners or onward connections) then simply cut any excess cable 50mm(2") longer than the profile (50mm/2" shorter than the wall).

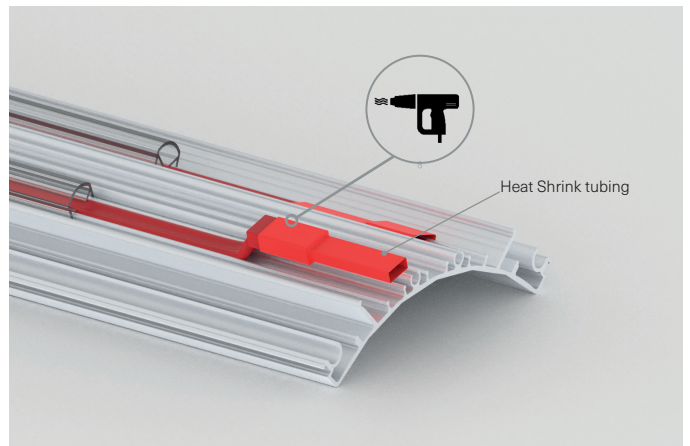

5. Using the silicone 'boots', RTV/silicone sealant and the heat shrink tubing, make safe the end of the cable.

Preparing the cable ends – Making a corner or onward connection

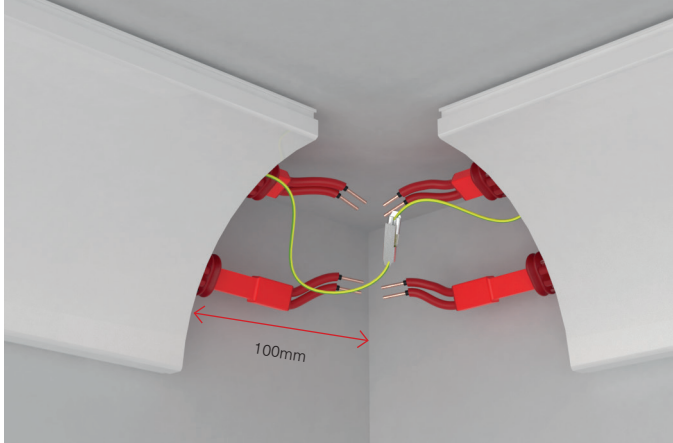

1. For an Internal Corner, the cable should be prepared as per the Power connection 9.1 – 100mm longer than the cut profile length (25mm/1" shorter than the wall length).

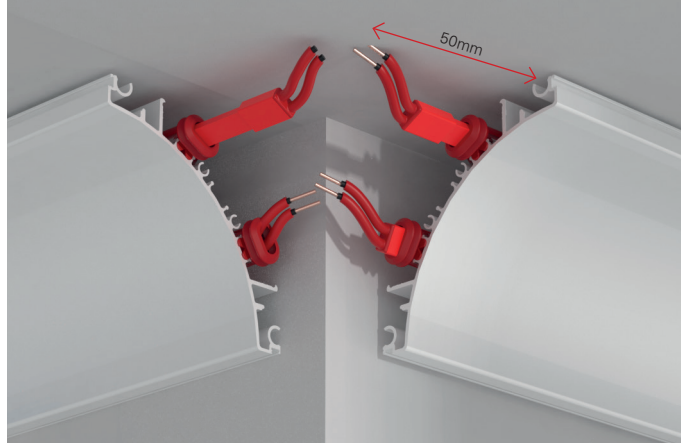

2. For an External corner, the cable should be prepared as per the Power Connection 9.1, but 25mm/1" longer than the wall (50mm longer than the cut profile).

Installing the Insulation panels



3. Protective gloves are recommended when handling the insulation panels, due to the nature of the material, which can cause skin irritation.

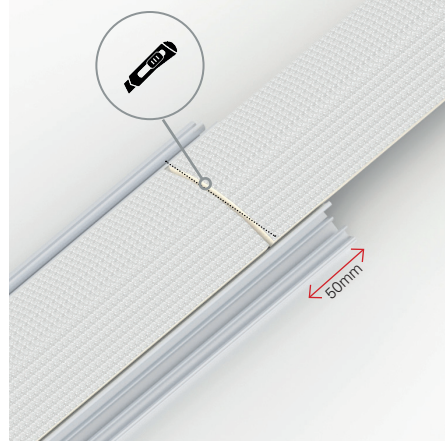

4. The insulation panels are supplied in 1500 x 100mm sections. They can be cut to size using a Stanley knife or sharp blade. The last piece should be cut to within 50mm of the end of the section.

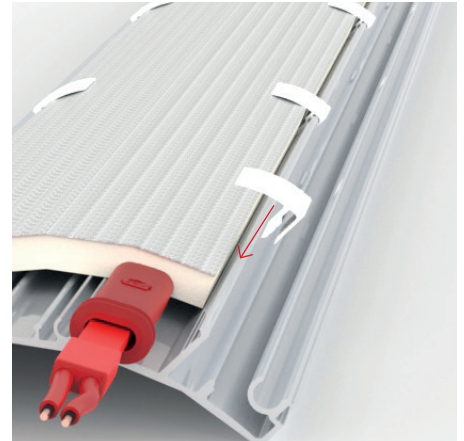

5. Once cut, they are secured in place using the insulation clips as shown.

Installing the 1st piece

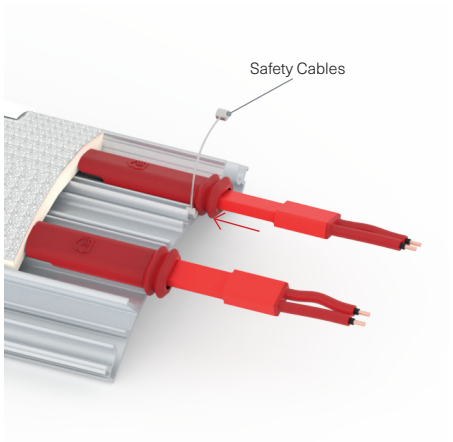

1. In the 2 wall brackets at either end of the run, insert the 100mm/4" safety cable line into the safety cable groove and secure with the 2 x 5mm Roll pins.

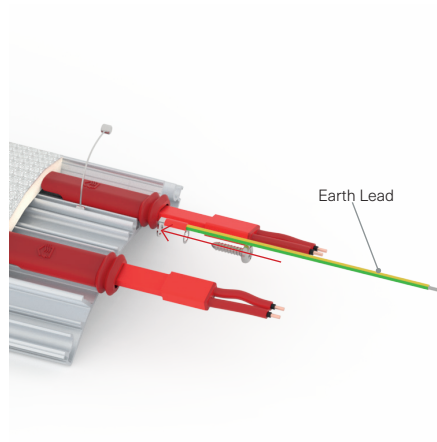

2. At the power connection end, DON'T forget to attach the EARTH lead into the lower/wall earth way using the 6mm self-tapping screw and serrated washer. (Make sure the cable is facing towards the wall to ensure the cover can be fitted later).

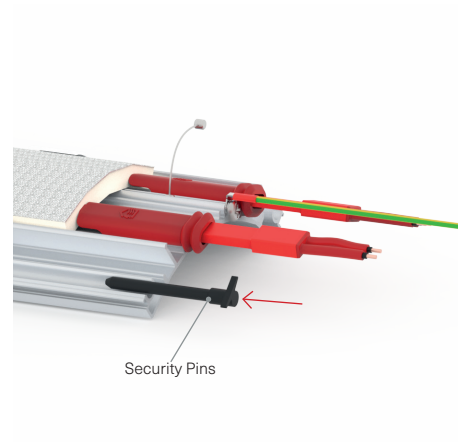

3. Insert the security pins into the lower/wall hinge point. There should be 3; One for each of the end and middle wall brackets. Note the security pins can also be 'squeezed' into the wall side hinge point groove.

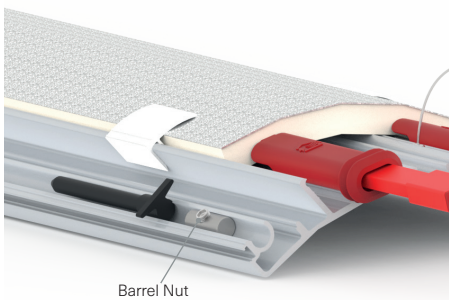

4. In the ceiling/upper side hinge point of the profile, insert the 8mm barrel nut to a depth of approximately 50mm/2" and loosely tighten the grub screw. This forms the expansion stop against the ceiling bracket and prevents cable connection damage.

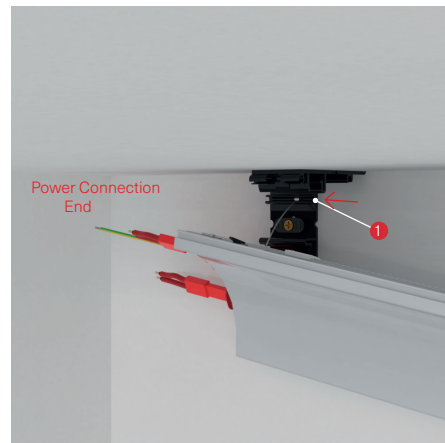

5. Using a hop up platform or ladder if required, raise the power connection end to the wall brackets. Insert the safety cable into the unused upper/ceiling Earth way, and retain with 1 x 5mm roll pin.



6. Leaving the power connection end hanging, move to the other end and repeat.

Installing the 1st piece



1. With both ends suspended, move to the middle and raise the profile to the wall bracket. Locate onto hinge point. A firm push may be required

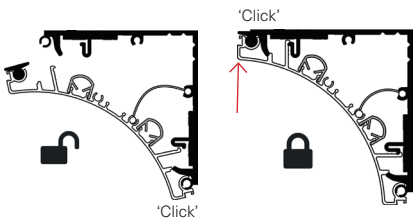

2. With the bottom hinge point secure, close up the profile to the ceiling bracket. Ensure the top hinge feature of the profile engages with the hinge point of the bracket. Again, a firm push may be required. If correctly installed, the ceiling bracket will slide backwards around 5mm, and the profile will lock securely to the bracket. NOTE: Slide the Security pins using a pick tool or prong until it slides into the hinge groove of both the wall and the ceiling bracket.

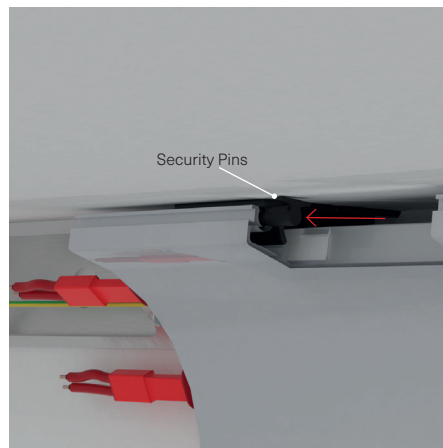

3. Move to the PCB connection end. The profile should be close to the ceiling bracket. Ensure there is good alignment of the hinge point and profile and push firmly home. Push home the Security Pins into the wall and ceiling brackets.

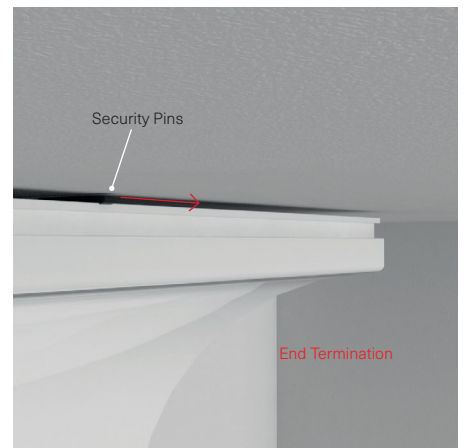

4. Repeat for far end. Push home the Security Pin. The 1st section is now secure and ready for electrical connection at the PCB end.

Connecting the Heating Cables & Earth

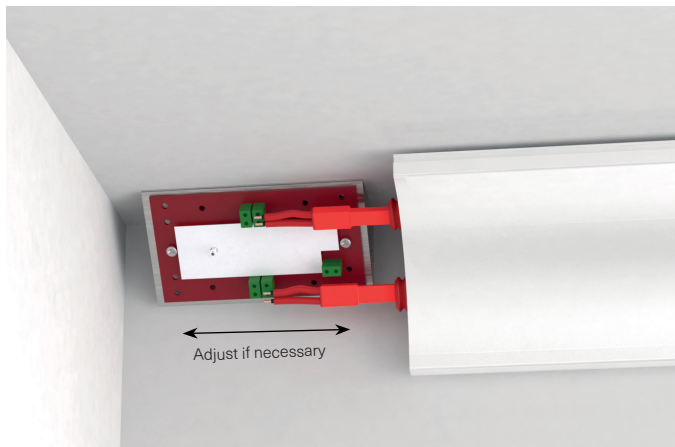

1. If cut and secured correctly the Trouser ends of the cable should be well located to reach the terminal blocks on the PCB. Adjust if necessary, by sliding the Easy bend bracket or alternatively carefully trim the trouser ends.

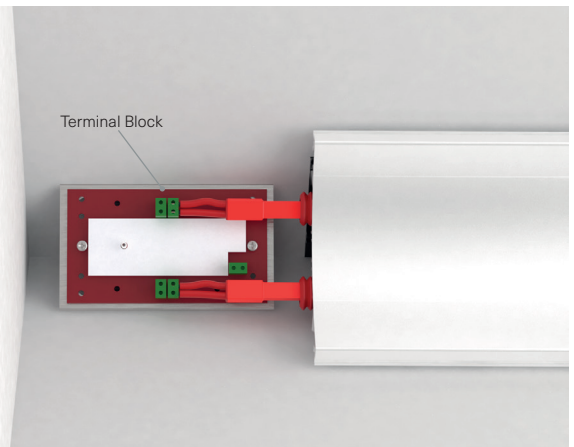

2. Connect the cables to the terminal. Do not over tighten to prevent damage to the terminal blocks.

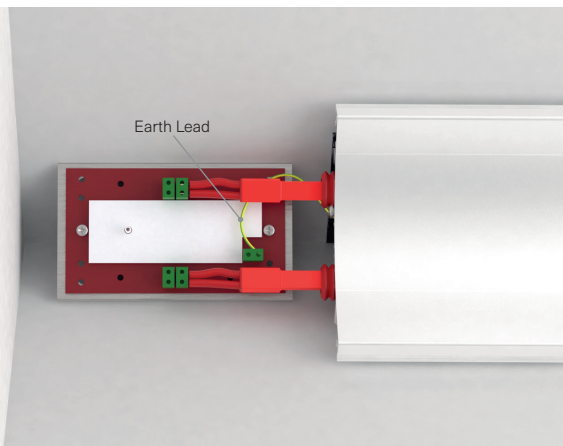

3. **EARTH CONNECTION!** For the safety of yourself and others and the protection of the system, the earth lead must be connected as shown.

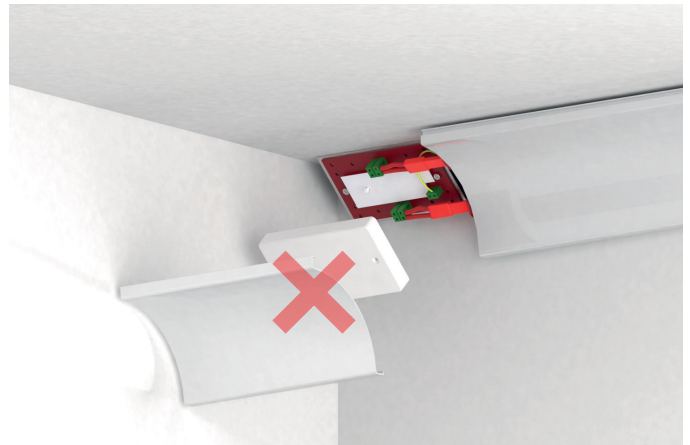

4. **DO NOT** fit the PCB cover and end covers until after the system has been connected and tested.

Fitting the Next Section(s) (if a single length only, skip to 16)

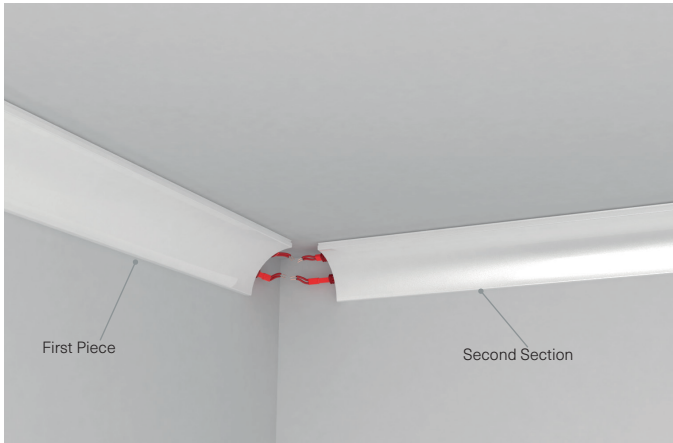

1. Using the same sequence as the first piece, install the second section onto the wall and ceiling brackets, using the clearances a shown in table 1.

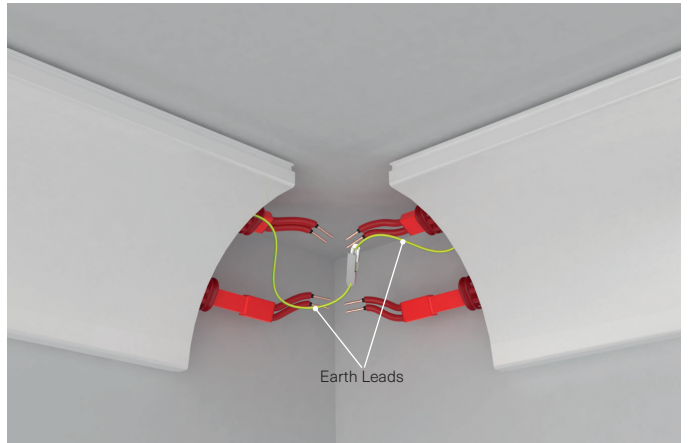

2. EARTH CONTINUITY! Ensure that the earth leads are securely connected using the saddle connectors and self tapping screws.

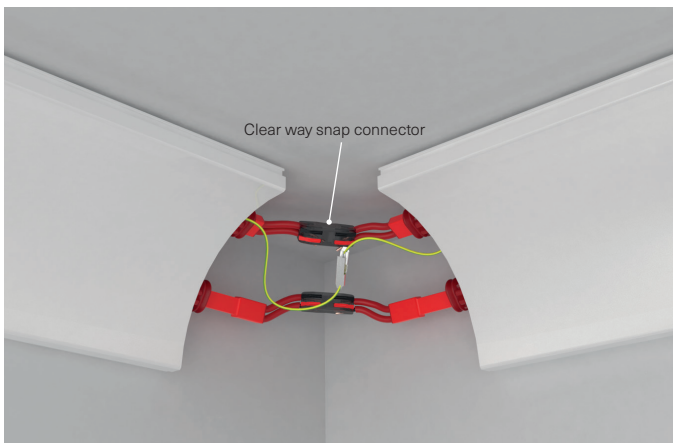

3. Connect the heating cables together using the clear 2 way snap connectors

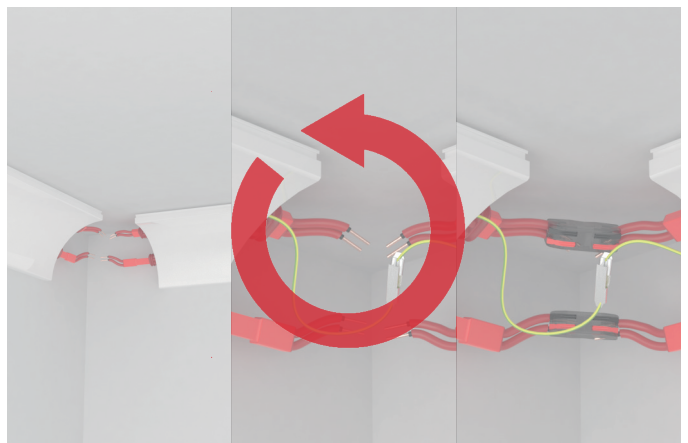

4. Repeat for additional walls and Sections.

Earth Continuity Testing

Using a test meter, ensure there is earth continuity right back to the PCB earth terminal. This is important for the safety of yourself and others and for the protection of the system.

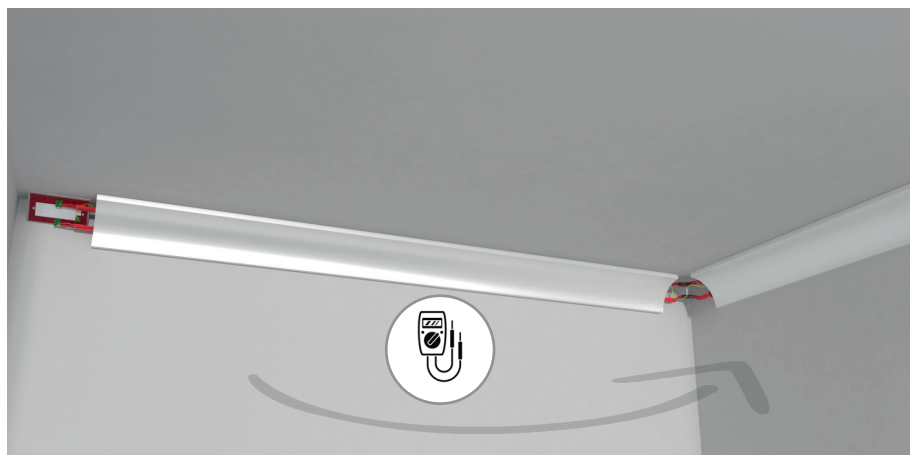

Testing & Energising the system 1st time

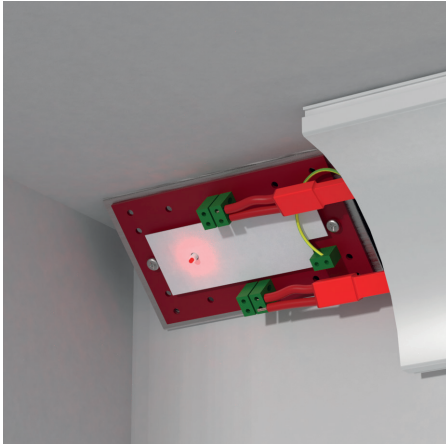

1. With all hands clear, power up the system from the Thermostat or control system. The red LED on the PCB will indicate power ON.

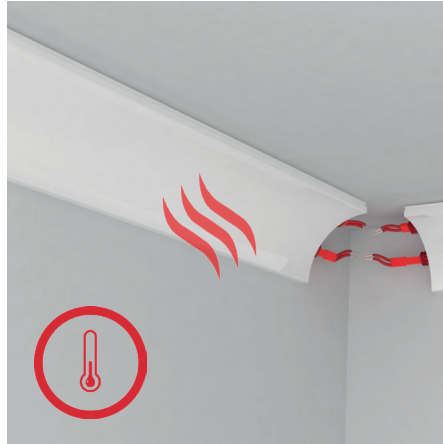

2. After 1~2 minutes, the surfaces of the ThermaCurve profile will feel warm. Check all sections are getting warm.



3. After 5 minutes, using a test meter, measure the voltage at each of the Terminal blocks. It should read 220~240VAC (mains voltage). (For the 1st 5 minutes the meter will read 100~120VAC as the system goes through its soft-start phase)

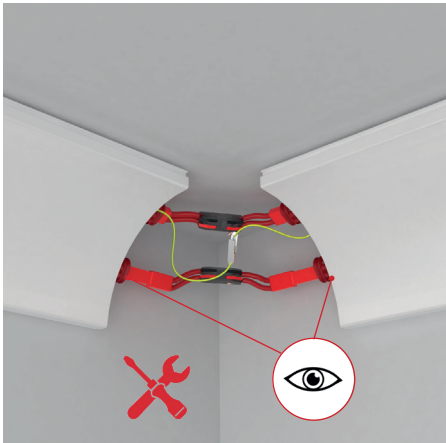

4. If all ThermaCurve sections are not warming after 5 minutes, power down and check any connections between profiles.

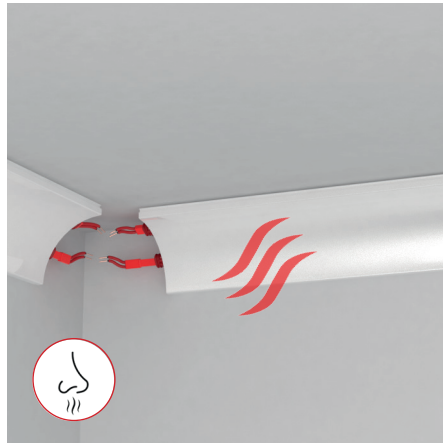

5. Note: on 1st energisation, there may be a slight aroma from the heating cables. This is normal and perfectly safe and will dissipate after an hour or two of operation.

Fitting the covers

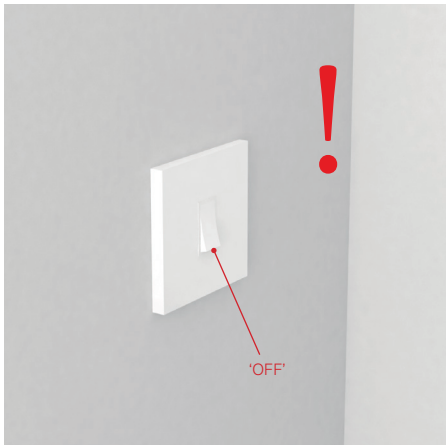

1. Power down so it is safe to work on the system.



2. Fit the PCB cover to the Easy Bend PCB bracket, using the self tapping screws provided.



3. Fit the Curved start end cover. This is best achieved by hooking over the top edge of the profile and pushing firmly over the bottom edge. The cover should fit snugly and securely.

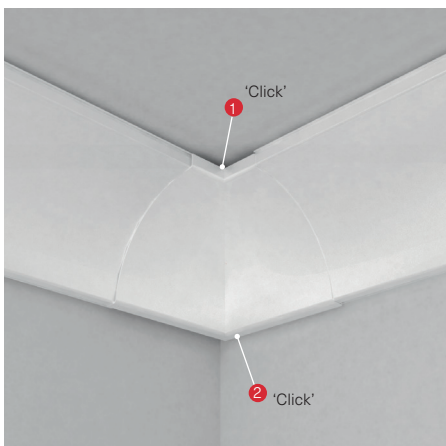

4. Corner covers are best attached by hooking over the longer edge first and pushing the shorter edge over afterwards (Internal corners: longer edge to the top, External: longer edge to the bottom).



5. It may be necessary to use a nail pry, jemmy bar or similar behind the edge of the profile to provide a firm leverage to push against as the covers are a snug fit.



6. The start and end covers should have at least 20mm (3/4") engagement on the profile to be considered secure.

Fitting the Sealing Gasket

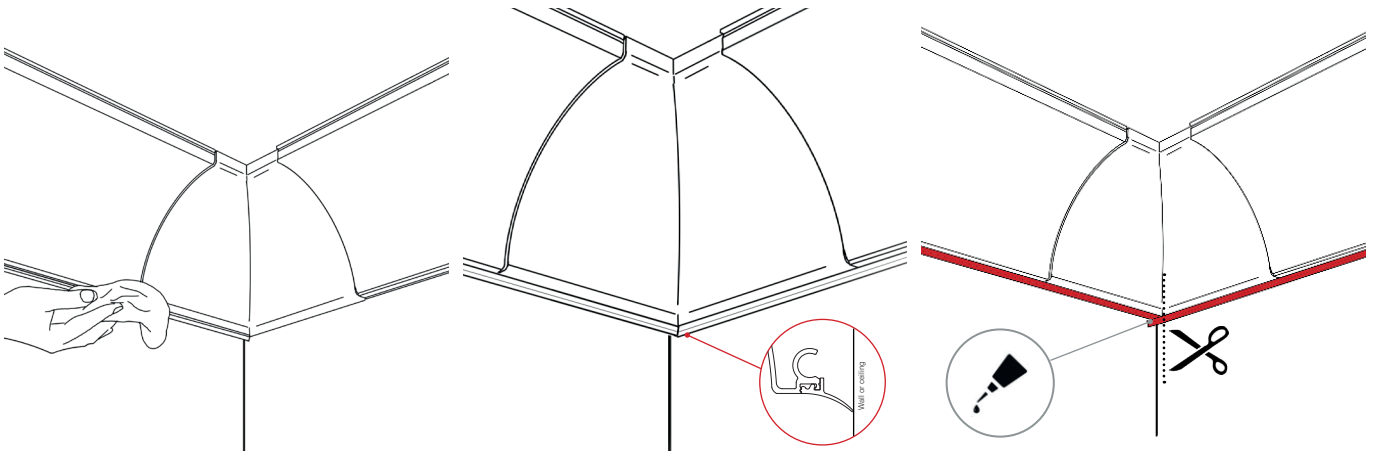

1. The sealing gasket (standard or wide option) are best inserted using a wet wipe/baby wipe to provide a slippery surface.

2. With the long leg to the wall/ceiling, feed in the gasket, and smooth using the wet wipe.

3. Trim ends to length. In the corners, cut at 45° and glue using instant, super glue or similar.

Fitting the Sealing Trim

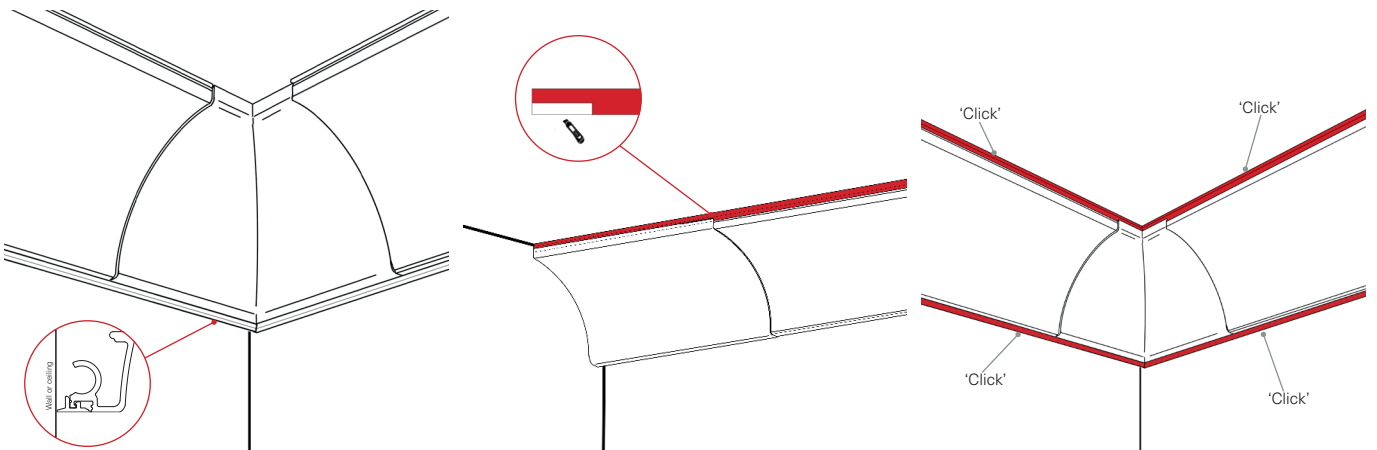

1. The sealing trim is inserted with the long 'leg' to the wall/ceiling side.

2. The 'soft' front edge needs trimming away to clear the covers. This is best achieved with a Stanley knife/box cutter at a shallow angle and slicing away from the body. Use the 'hard' front leg as the blade guide.

3. The sealing trim is then clicked into the profile and butt jointed in any corners.

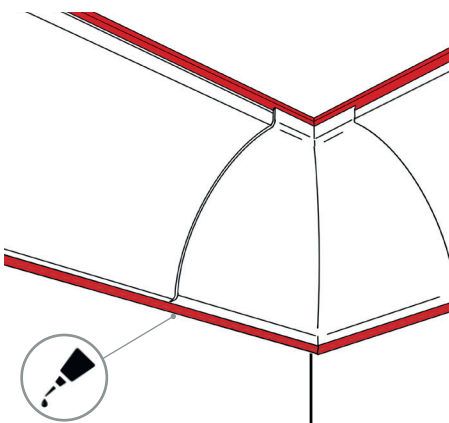

4. The system can then be sealed in using a temperature resistant sealant (>150°C/300F).

Fitting the Capping.



1. The Capping mounting rail is cut to length and then clicked into the ThermaCurve profile.



2. The mounting rail should be secured to the wall/ceiling using appropriate fixings every 600~1000mm (2~3')

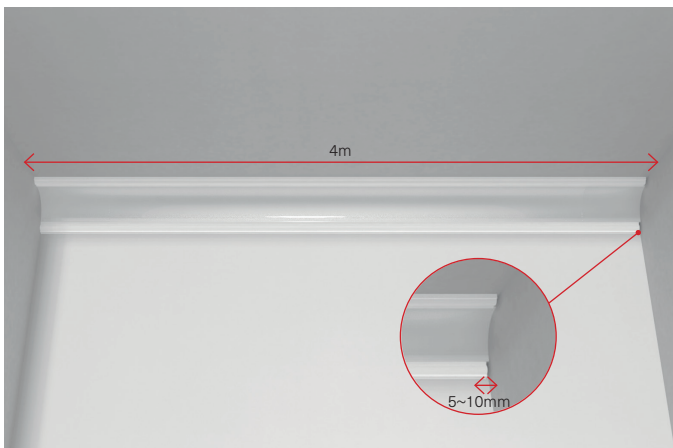

4. The profile capping can be cut to the wall length. For long straight lengths > 4m allow 5~10mm (1/4"~3/8") for expansion

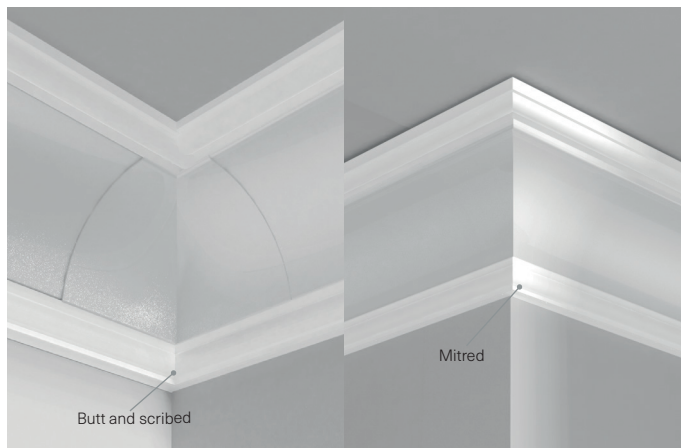

5. Internal corners: Capping should be butt and scribed (like skirting boards). For external corners, the capping should be mitred

Trouble Shooting

If the cable has been damaged during or after installation, the system will trip out due to an earth fault. The damage to the cable needs to be located and repaired. The normal sequence would be:

- A) Isolate Power before removing any covers or skirting panels**
- B) Remove end connection and termination covers first to check the cable ends for damage**
- C) Remove any intermediate stainless covers to check the cables for damage at any junctions**
- D) Starting from one end . remove the heating panels in sequence , checking the back for any signs of Damage to the cable covers and cable**
- E) Remove the cable covers in sequence and check the heating cable for signs of damage**

Usually, any damage to the front of the cable outer red sheath will cause an earth fault to the aluminium heating panel. Damage to the back face of the cable cover side) will not ordinarily cause an earth fault as the cable covers are an insulator, unless the cable cores have been cut and exposed or compressed together.

If the damage to the heating cable is slight (red outer sheath damage, black core exposed) then it can be repaired using the red heat shrink tubing in the spares kit (see 13.1). If the heating cable is badly damaged (black core damaged, conductor exposed) then that section must be replaced (see 13.2).

If the outer sheath has been damaged at a junction, double check the cable channels have been opened up and deburred at each end.

13.1 Repair to Outer Sheath

Included in the spares kit are several lengths of toughened heat shrink sleeving which can be slid over the cable to the damaged section and heated into place. The cable will be able to be squeezed back into the cable channel although it will be a tight fit. The cable cover may need to be modified locally in order to fit. Check the cable channel for any signs of sharp edges or debris that may have caused the damage and rectify before replacing the cable.

13.2 Replacing a section of cable

If the damage to the cable has exposed the metal conductor cores then that section must be cut out and replaced. If the damage is near to the end, it may be simpler to cut the cable short and insulate using the heat shrink sleeving and termination boots. NB: The black heating core and conductors cannot be allowed to be in contact with the aluminium or exposed to the touch as they are 'live'. If the damage is mid sections, and/or in more than one place it is recommended to replace that section of cable with a complete new piece, joining and insulating the cables at the corner junctions.

Maintenance

Routine maintenance if your ThermaCurve system is not required, except for perhaps a wipe down to remove any dust or marks that a traditional skirting board might accrue over time.

For further assistance please contact DiscreteHeat Co. Ltd on **01942 88 00 60** or email **info@discreteheat.co.uk**



DiscreteHeat Company Limited

1 Victoria Works Industrial Estate,

Atherton, Manchester, M46 0FY.

www.discreteheat.com

0845 123 8367

